

ER32

CAT50 & Straight Shank ER32 Collet Chucks

(Balanced to G2.5@15,000 RPM)



- Small diameter nose well-suited for working in close quarters
- Increased flexibility for milling, drilling, and reaming
- Flush precision collet nut, grips tool close to cutting edge for accuracy and rigidity
- Concentric to .0002" TIR puts tool precisely on spindle center line
- AT3 or better shank taper allows for accurate, rigid toolholder-to-spindle mount
- Wide range collets reduce collet and toolholder inventories
- Fully ground flange and V-groove is easy on tool changers for less spindle and changer maintenance
- Through spindle coolant standard
- [ER32 Collets found on pages 608-609.](#)

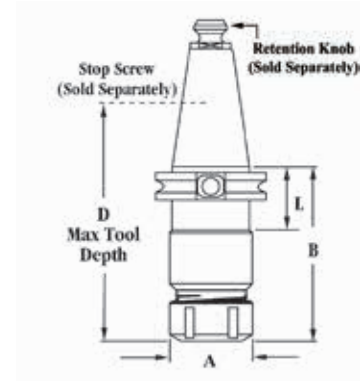





CAT50 ER32 Collet Chucks

Capacity	Taper	A	Gage Length (B)	D	L	Max. Nosepiece Torque	Part #
.079-.787	CAT50	1.97	4.00	4.00	1.38	48 ft lbs	RC5ER324000
.079-.787	CAT50	1.97	6.00	4.00	1.38	48 ft lbs	RC5ER326000
.079-.787	CAT50	1.97	8.00	4.00	1.38	48 ft lbs	RC5ER328000

ER32 Straight Shank Collet Extension

A	B	D	L	Photo	Dimensions	Part #
1.97	7.5	1.25	5.5			RSSER32750

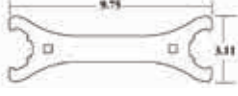
ER32 Parts & Accessories

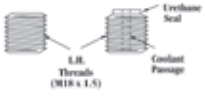
Description	Photo	Dimensions	Part #
ER32 Replacement Nosepiece			RER32NPA
ER32 Collet Wrench [†]			RER32W
ER32 Stop Screw			RER32SS
ER32 Stop Screw Coolant Thru			RER32SSC

[†]Required for assembly.